

CURVE AN SELECT L

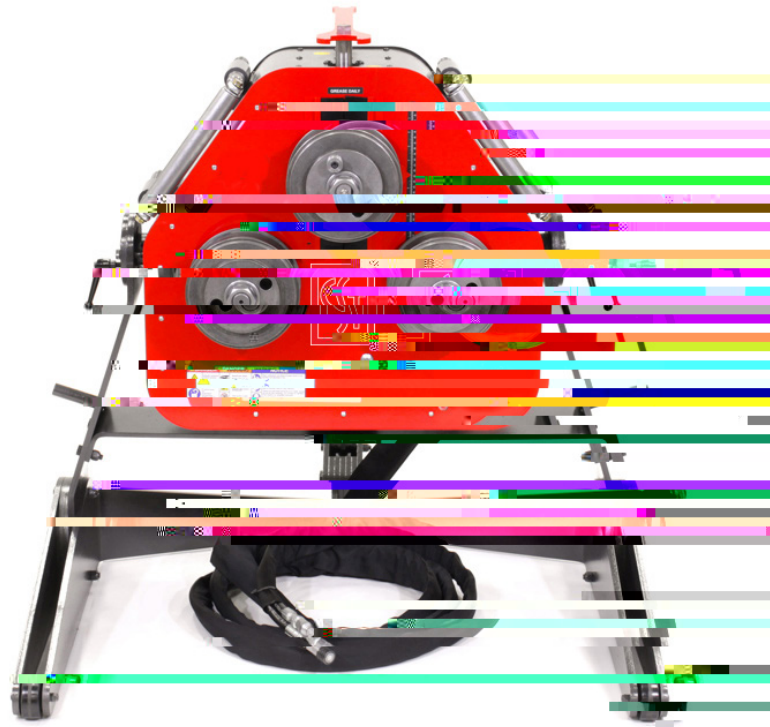

Radius Roller Manual

- 1 Company Profile, Warranty
- 2 Operator and Supervisor Information
- 3 Environmental Requirements
- 3 Receiving/Unpacking/Moving
- 4 Installation
- 4-5 Signal DeTm[12 0 jEMCEMOC/Spom Lang (en-US)62CID 15 B6BT0 Tw 12 0 0 12 87 595.6321 Tm(4-5

Radius Roller

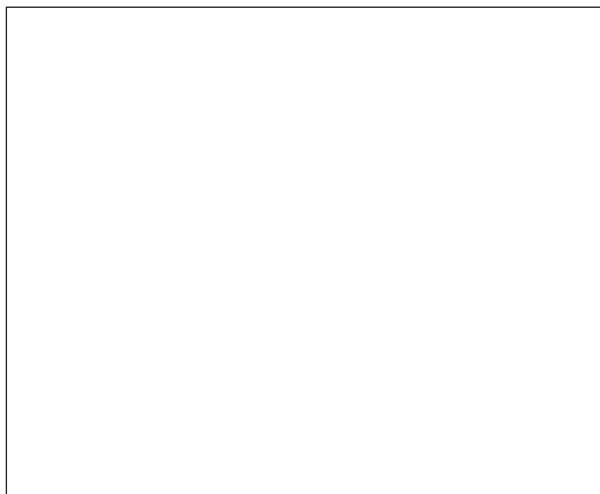
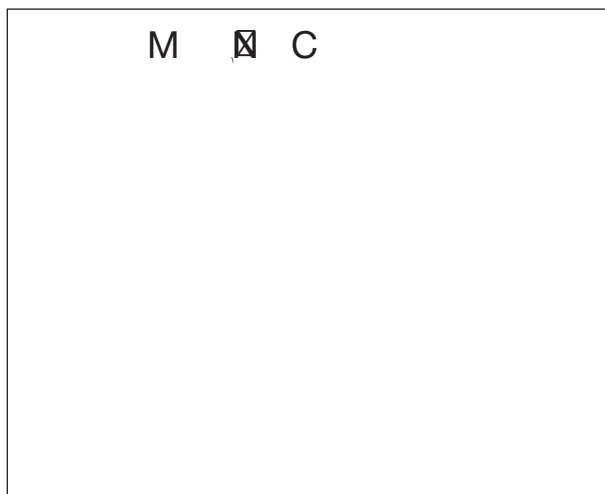

Designed for medium to heavy material, the Radius Roller powers through your job quickly and accurately. Roll rod, flat, angle and channel. The variable speed, hydraulic drive allows you to "dial in" the appropriate speed for various materials. Quickly change the orientation from vertical for smaller projects to horizontal for those larger, heavier jobs.



HYDRAULIC SPECIFICATIONS

PORTA POWER

5 HP Hydraulic Power Unit

M ☒	S
Standard Electric Motor	5HP, 3 Phase, 208V/230V
Optional Electric Motor	5HP, 3 Phase, 460V 5HP, 1 Phase, 230V
Pump Size	3-1/2 gpm-single stage
Valve Pressure	3,000 psi
Reservoir	7 Gallons



Company Profile

The Cleveland Steel Tool Company offers a full line of high quality, low maintenance hydraulic ironworking machines, associated tooling and accessories that are used in the steel fabrication industry. With proper operation, care, and maintenance, your Cleveland Steel Tool Radius Roller will provide years of safe, trouble-free service. Please take time to study this manual carefully to fully understand Radius Roller safety procedures, set-up, operation, care, maintenance, troubleshooting and warranty coverage prior to putting the machine into production. Any questions not answered within this manual can be directed to The Cleveland Steel Tool Company.

474 E. 105th St.

WARNIN

Receiving Radius Roller





This manual provides installation requirements for the Cleveland Steel Tool Radius Roller.

All Cleveland Steel Tool hydraulic accessory tools are powered by a Cleveland Steel Tool Ironworker or a Cleveland Steel Tool Porta Power, portable hydraulic power unit.

Refer to the manual for the Cleveland Steel Tool Porta Power to operate your Cleveland Steel Tool hydraulic accessory tool. Provide operators with sufficient training and education in the basic functions of the machine prior to machine operation.

E  R  W  S





The work station environment for your Cleveland Steel Tool Radius Roller must meet the following minimum requirements:

- A   : 45°F - 110°F
- R  : No greater than 90% relative humidity.
- F   : Assure that the machinery work area is free of debris



Daily Maintenance

WARNING

D     .
Check wiring harness for loose connections or damaged control wiring.

Replace damaged control wiring as necessary. Order replacement control wiring assembly from Cleveland Steel Tool.

Check hydraulic fittings and hoses for wear or damage. Replace damaged or worn hydraulic hoses and fittings as necessary. Order replacement hydraulic components from Cleveland Steel Tool.

Check bolted connections and secure as necessary.

Check welded connections.

Check bearing surface quality.

Visually inspect die surfaces for chips or galling in the bearing surface.

Verify tooling is secure. Cleveland Steel Tool tooling is manufactured from billet steel for enhanced strength and durability. These are wearing parts that will fail over time and will require replacement. Order additional tooling through Cleveland Steel Tool. Install replacement parts according to this manual.

Clean your Radius Roller daily. Disconnect the unit from its power source first. Do not use liquid cleaners, aerosols, abrasive pads, scouring powders or solvents such as benzene or alcohol. Clean your machine with a compressed air nozzle and soft cloth lightly moistened with a mild, water-based detergent solution. Remove filings, dirt, dust and grime from working surfaces. Ensure the surfaces are fully dry before reconnecting power.

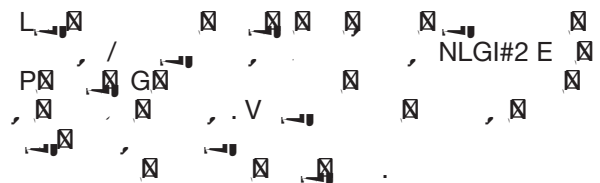

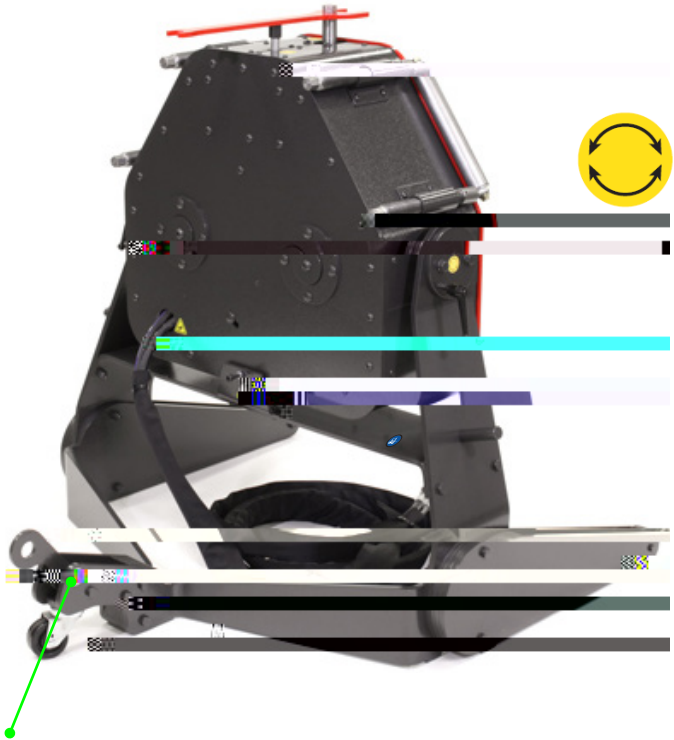
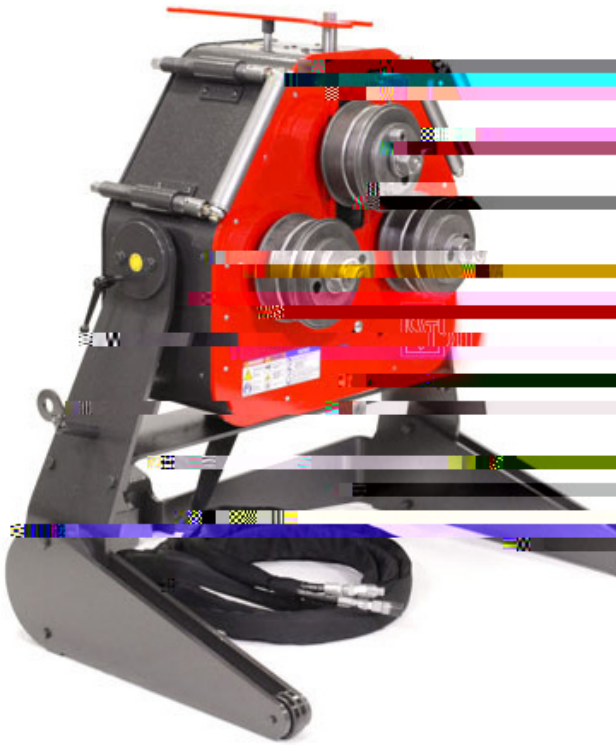

 **WARNING**

Operations Diagram

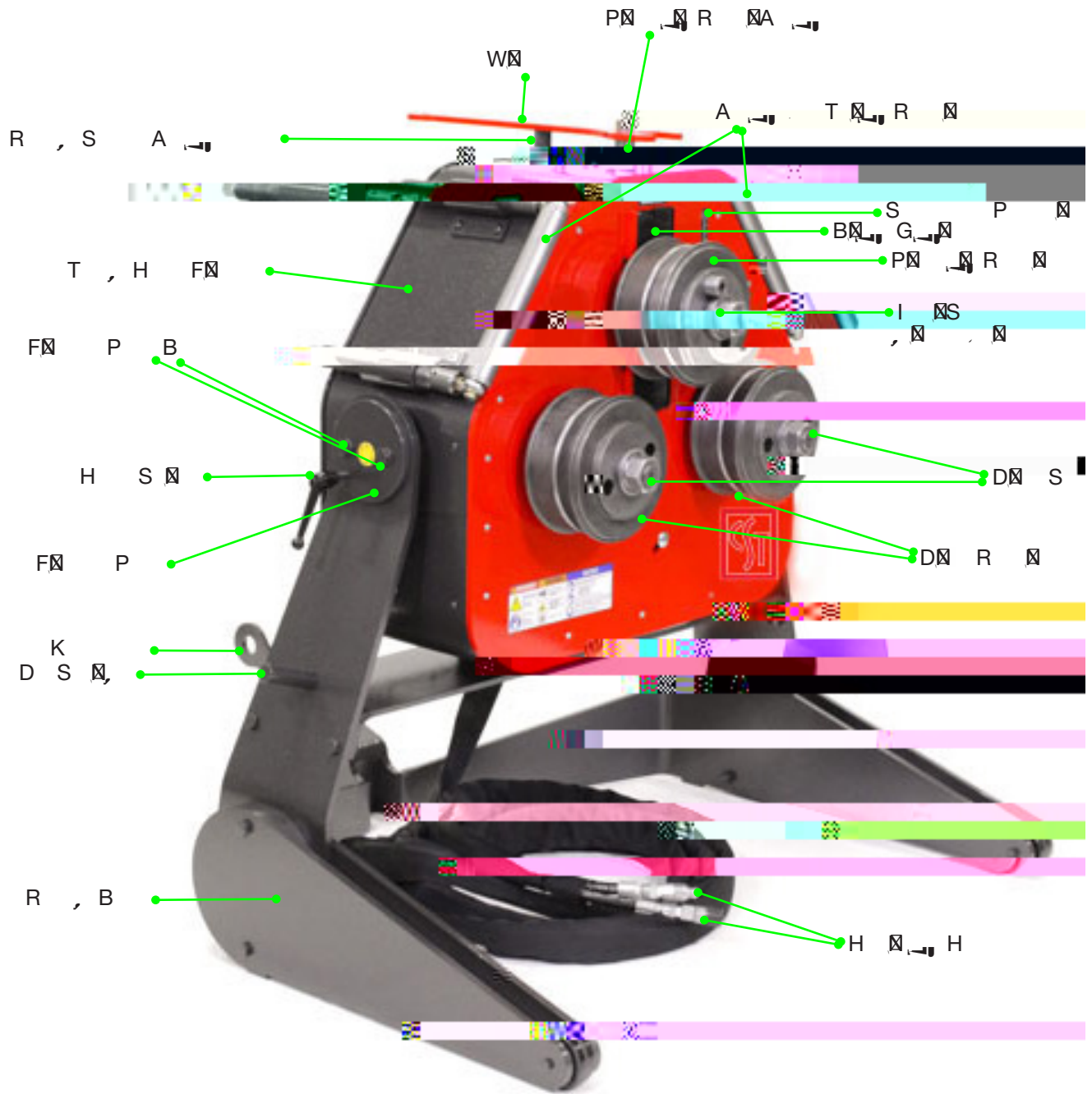

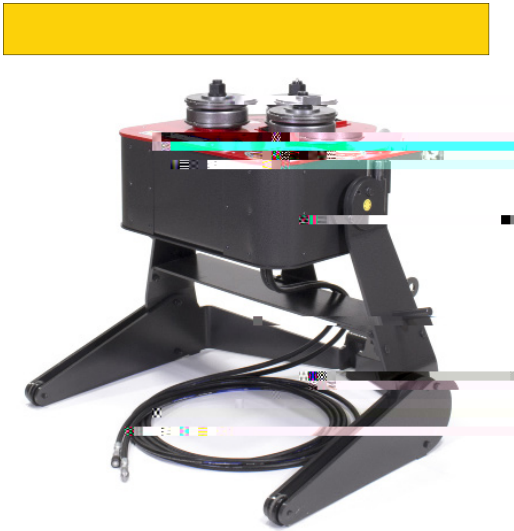

Horizontal Operating Position

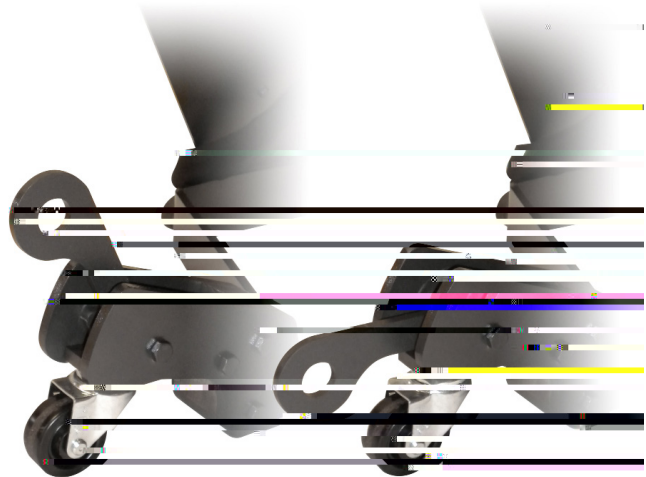

Left: Kickstand up (disengaged) Right: Kickstand down (engaged)

B O ☒

The heavy duty, 1/2" formed steel plate design is balanced like a tripod and rolls on 3 wheels. The "kickstand" at the rear of the Radius Roller base allows you to push the kickstand down with your foot to deploy the swiveling caster and easily roll the bender to your work station. When located in the ideal location, flip the kickstand up to disengage the swiveling caster and stabilize the Radius Roller on the floor.



Vertical Operating Position

T , H -F☒ O ☒

The head-frame of your Cleveland Steel Tool Radius Roller is mounted with a yoke and pin to a sleeve and stop mechanism in the roller stand. This mounting configuration allows for the Roller enclosure to be operated in either a horizontal or vertical orientation. Positive stops at 0 and 90 degrees provide for a flexible and stable operation of the roller when working with light or heavy weight shapes or long setups.

Rotate the tilting head frame with caution. To rotate the head frame, release the hand screw on the sides of the rotational sleeves. Release the four friction plate bolts (do NOT remove).

Rotate the tilting head frame by lifting from the base of the roller. Once the roller is in its horizontal position, secure the hand screws on both yokes into their respective detent locations. For extra support of the enclosure, tighten the four 1/2" bolts on the friction plates. To return to vertical, repeat this sequence in reverse while supporting the head frame to its vertical resting place.

Roll Forming

L , M ☒

Prepare your work by cleaning the material and die surfaces.

Rotate and secure the roller head frame in either the vertical or horizontal working position. If working with long sections of material, be prepared to support your material with a material rest or roller stand (provided by user). Place the material to be formed on top of the two drive roll dies. Adjust dies to accommodate material size. Capture the material within the drive rolls by nesting the drive roll sets and spacers.

Bring the pressure roll down to meet the material being formed.

With the roller dies configured to the material, tighten the dies onto the drive and idler shafts with the wrench provided. **DO NOT OVERTIGHTEN SECURING NUTS TO SHAFTING.**

LUBRICATION

Adjust the pressure roll to capture the material being roll formed by nesting the roll set and spacer.

Rolling Common Sections

ROLL FORMING FLAT SECTIONS

Roll forming is a multi-pass process. Patience and test material are required to provide for a successful part.

Identify your target profile by creating a full scale template of the proposed radius. With your radius template or profile gauge available, lay your material over the coordinated drive dies. Lower the pressure roller to meet the surface of your section. Apply additional pressure to the section to gently prebend the material. Prebending the material will be seen as raising the tail stock of your section. **DO NOT**

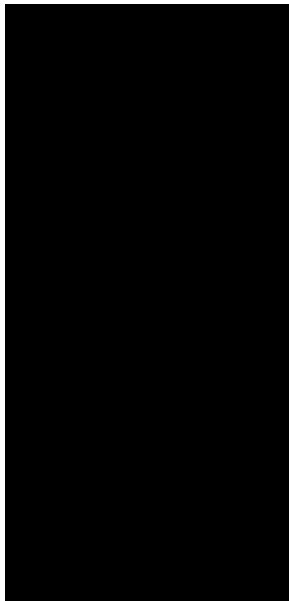

Troubleshooting

WARNING

Quality parts are dependent upon conscientious setup, operation and maintenance of your Radius Roller. Physically review your Radius Roller prior to any operation. Confirm all static components are tight in the assembly. Confirm all moving components are free of obstruction. Confirm all tooling and assemblies are properly seated within the assembly.

Problem

Solution

Roller Inoperable

Check accessory control switch at Ironworker
Check Roller mil. spec. control cable is connected to female mil. spec. port.

Check variable speed control. Check E-Stop button at Ironworker, Porta Power, or accessory hand control.

Note: Auto Cut port will NOT power the Radius Roller accessory.

Rough Roller Operation

Check Hydraulic fluid level at power source.
Check variable speed control

